

VP23, 3-way Proportional pressure control valves seat valve with μ P-driven pressure control

- Port size: G1/4 ... G3/4
Nominal size: DN8 and DN16
- Pressure ranges 0...2, 0...10 and 0...16 bar
- Microprocessor-controlled closed-loop controller
- Setpoint: 4 to 20 mA, 0 to 10 V, IO-Link

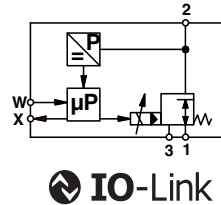

Technical features

Medium:

Filtered (50 μ m), unlubricated or lubricated condensate-free compressed air or neutral gases
Due to the lubricants and their additives, use of lubricated compressed air can affect the dynamics and service life

Operation:

Proportional solenoid

Input pressure range, P1:

The minimum input pressure (P1min) must be at least 1 bar higher than the required output pressure (P2). However, the maximum input pressure (P1max) must not exceed 7 bar, 12 bar, and 17.5 bar for units with output pressure ranges of 0...2 bar, 0...10 bar, and 0...16 bar, respectively.

Operating pressure P2:

0 ... 2 bar (0 ... 29 psi)
0 ... 10 bar (0 ... 145 psi)
0 ... 16 bar (0 ... 232 psi)

Flowrate:

See flow characteristics

Flow direction:

1 \rightarrow 2, 2 \rightarrow 3

Service life:

> 10 Million operations, max. stroke

Linearity:

< \pm 1,0 % (p2 max.)

Control accuracy:

< \pm 1,0 % (p2 max.)

Response accuracy:

< \pm 0,2 % (p2 max.)

Hysteresis:

< \pm 0,5 % (p2 max.)

Repeat accuracy:

< \pm 0,5 % (p2 max.)
values related to 20°C and 24 V d.c. power supply

Ambient:

Valve series is designed for indoor use at normal industrial ambient

Ambient/Media temperature:

Media
-5 ... +50°C (+23 ... +122°F)
(no condensation permitted)
Ambient
-5 ... +60°C (+23 ... +140°F)
Air supply must be dry enough to avoid ice formation at temperatures below +2°C (+35°F).

Materials:

Valve housing: Aluminium
Electronic housing: PAA
Seals: NBR, HNBR on request
Internal parts : PBT
Springs : Steel

Technical data, standard model

Symbol	Output pressure range	Nominal size DN	Max. Flow (l/min)	Set point (input)	Actual value (output)	Weight (kg)	Model
	0 ... 2 bar	8	850	0...10 V	0...10 V, 4...20 mA	1,1	VP2302BD761MB200
	0 ... 2 bar	8	850	4...20 mA	0...10 V, 4...20 mA	1,1	VP2302BD461MB200
	0 ... 2 bar	8	850	IO-Link	IO-Link	1,1	VP2302BDLL1MB200
	0 ... 2 bar	16	3.500	0...10 V	0...10 V, 4...20 mA	1,7	VP2302BE761MB200
	0 ... 2 bar	16	3.500	4...20 mA	0...10 V, 4...20 mA	1,7	VP2302BE461MB200
	0 ... 2 bar	16	3.500	IO-Link	IO-Link	1,7	VP2302BELL1MB200
	0 ... 10 bar	8	2.500	0...10 V	0...10 V, 4...20 mA	1,1	VP2310BD761MB200
	0 ... 10 bar	8	2.500	4...20 mA	0...10 V, 4...20 mA	1,1	VP2310BD461MB200
	0 ... 10 bar	8	2.500	IO-Link	IO-Link	1,1	VP2310BDLL1MB200
	0 ... 10 bar	16	12.500	0...10 V	0...10 V, 4...20 mA	1,7	VP2310BE761MB200
	0 ... 10 bar	16	12.500	4...20 mA	0...10 V, 4...20 mA	1,7	VP2310BE461MB200
	0 ... 10 bar	16	12.500	IO-Link	IO-Link	1,7	VP2310BELL1MB200
0 ... 16 bar	8	3.000	0...10 V	0...10 V, 4...20 mA	1,1	VP2316BD761MB200	
0 ... 16 bar	8	3.000	4...20 mA	0...10 V, 4...20 mA	1,1	VP2316BD461MB200	
0 ... 16 bar	8	3.000	IO-Link	IO-Link	1,1	VP2316BDLL1MB200	
0 ... 16 bar	16	14.000	0...10 V	0...10 V, 4...20 mA	1,7	VP2316BE761MB200	
0 ... 16 bar	16	14.000	4...20 mA	0...10 V, 4...20 mA	1,7	VP2316BE461MB200	
0 ... 16 bar	16	14.000	IO-Link	IO-Link	1,7	VP2316BELL1MB200	

Option selector

VP23★★B★★★1★★★

Output pressure range	Substitute
0 ... 2 bar	02
0 ... 10 bar	10
0 ... 16 bar	16
Nominal size	Substitute
DN8	D
DN16	E
Set point	Substitute
4 ... 20 mA	4
0...10 V	7
IO-Link	L

Option	Substitute
Serial interface	B200
Connector	Substitute
M12	M
8 pin analogue Version	
5 pin IO-Link Version	
Actual value	Substitute
0 ... 10 V/4 ... 20 mA	6
IO-Link	L

Note: IO-Link cannot be combined with an analogue version

Function

The electronic pressure regulator is used for quickly and precisely set an output pressure on port 2 according to a specified setpoint (control signal). Even with consumption of the medium (compressed air or neutral gases) the output pressure is retained constantly.

Proportional valves are used in many different applications across all sectors of industry. They are used anywhere where precise and fast, direct or indirect control of pressure, force, rotational speed etc. is required.

Design

The electronic pressure regulator consists of:

- Proportional solenoid
- pneumatic spool
- integrated pressure sensor
- Microprocessor driven controller
- USB-Interface

Configuration Software VP-Tool available on our Website.

Operating principle

The valve operates with a closed loop, thus the output pressure is constantly measured by the internal pressure sensor and compared with the specified setpoint.

If the output pressure is lower than the specified output pressure or if a higher output pressure is specified, the pneumatic controlled plunger is actuated by the proportional solenoid. A connection between port 1 (inlet pressure) and port 2 (output pressure) is established until the output pressure corresponds to the specified setpoint.

If the output pressure is higher than the specified pressure set via setpoint, or if a lower pressure is required, the force on the control plunger is reduced by the proportional solenoid.

A connection between port 2 (outlet pressure) and port 3 (venting) is established, until the output pressure corresponds to the specified setpoint.

After switching off the supply voltage the last specified outlet pressure is vented down to 0 bar.

Fatigue strength against sinusoidal oscillations according to DIN EN 60068-2-6: 10g at 10-500Hz in the switched-off state.

Durability under shock conditions according to DIN EN 60068-2-27: 30 g/10 shocks

Valves cannot be used in safety systems that require shut-off or venting valves.

Without power supply, pneumatic port 2 -> 3 is open

Electrical Parameters

Supply

Supply Voltage	UB resp.. VA and VS	18 ... 32 V DC
Residual ripple	[%]	10
Current consumption at 24V	Maximum, dynamic. [A]	< approx. 2,0 A
	static (balanced) at 25°C [A]	< approx. 0,7 A

Inputs (Signal)

Setpoint W (U/I switchable)

Setpoint W (U) analogue differential (V)	0 ... 10
Inputresistance RI (kΩ)	> 100
Setpoint W(I) analogue:	0 ... 20 / 4 ... 20 (default)
Current signal (mA) Burde (Ω)	500
Max. Voltage Input (V)	-10 ... 40

Pressure Feedback Signal X(I)

Current signal of the pneumatic Output pressure (mA)	0 (4) ... 20 mA = 0 ... max. p2
Load resistance RL (Ω)	500 recommended

Outputs (Signal)

Pressure Feedback Signal X(U)

Voltage signal of the pneumatic Output pressure (V)	0 ... 10 V = 0 ... max. p2
-----------------------------------------------------	----------------------------

Output "Pressure reached" X (comparator)

Switching range (% max. p2)	+/-2% (default)
Digital output signal	SPS- Pegel (PLC- Level)
Outlet pressure out of the Switching range (X≠W)	Low (0V)
Pressure reached (X = W) (V)	High (+24V nom.)
Output current max. (mA)	10

Pneumatic parameters

Recommended application area by nominal size:

DN8: Volume (closed) from 100 ... 1500 cm³

DN16: Volume (closed) from 1000 ... 8000 cm³

Residual ripple max.	[%]	10
Input pressure p1 max.	[bar]	17/12/7
Output pressure p2 max.	[bar]	0-16 / 0-10 / 0-2
Flow quantity DN8	[l/min]	see diagram
Flow quantity DN16	[l/min]	see diagram
Switching times (10%-90%) nominal size 8 at volume 400 cm ³		
Typical values for P1=12 bar		
Pressure build-up (tr) 1 bar ... 9 bar		100 [ms]
Pressure build-up (tf) 4 bar ... 5 bar		50 [ms]
Pressure drop (tr) 9 bar ... 1 bar		250 [ms]
Pressure drop (tf) 5 bar ... 4 bar		50 [ms]
Switching times (10%-90%) nominal size 16 at volume 1000 cm ³		
Typical values for P1=12 bar		
Pressure build-up (tr) 1 bar ... 9 bar		100 [ms]
Pressure build-up (tf) 4 bar ... 5 bar		50 [ms]
Pressure drop (tr) 9 bar ... 1 bar		100 [ms]
Pressure drop (tf) 5 bar ... 4 bar		50 [ms]

Test assembly flow

CETOP RP 84 P: flow characteristic of pneumatic devices

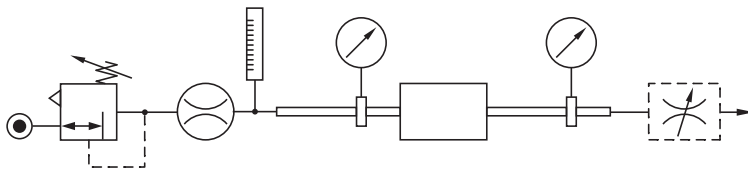

Step-response diagram

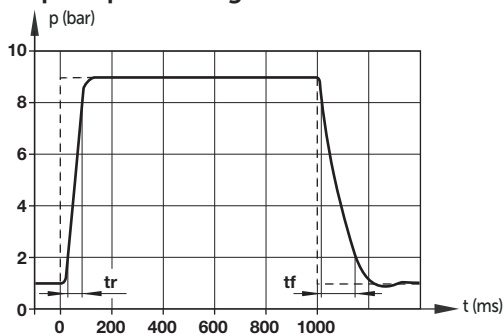

Pneumatic characteristics curves

Static characteristics

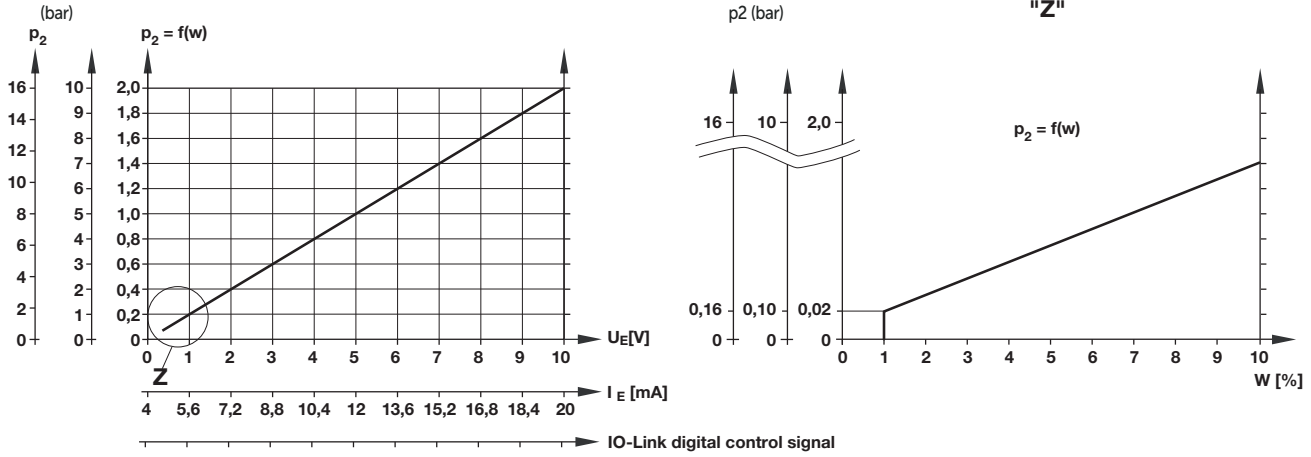

Flow rate characteristic as a function of the set-point (voltage/current/digital IO-Link) and input pressure 7 bar, 12 bar, 17 bar for nominal size DN8 and DN16

Flow rate characteristics DN8/P1=7 bar, 12 bar, 17 bar

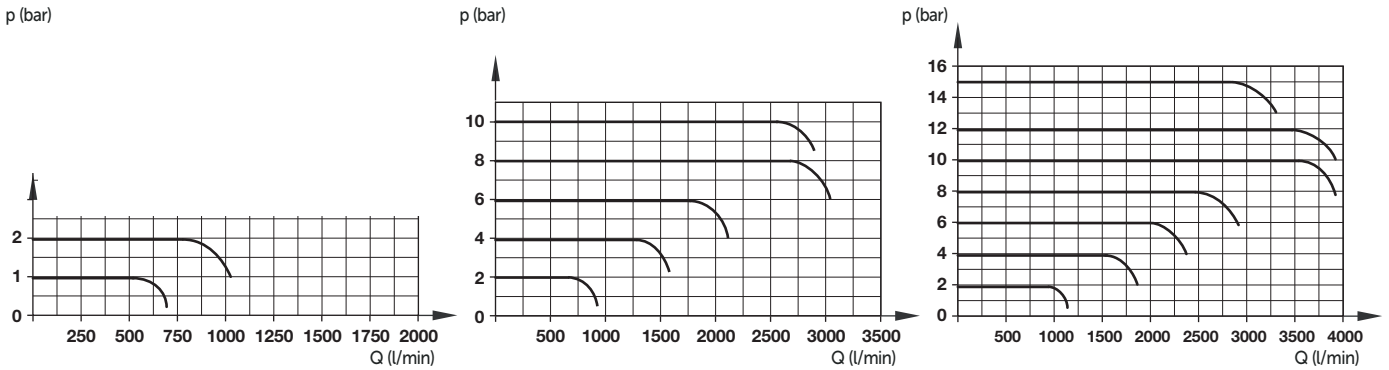

Flow rate characteristics DN16/connection plate 1/2" (DN12); P1=7 bar, 12 bar, 17 bar

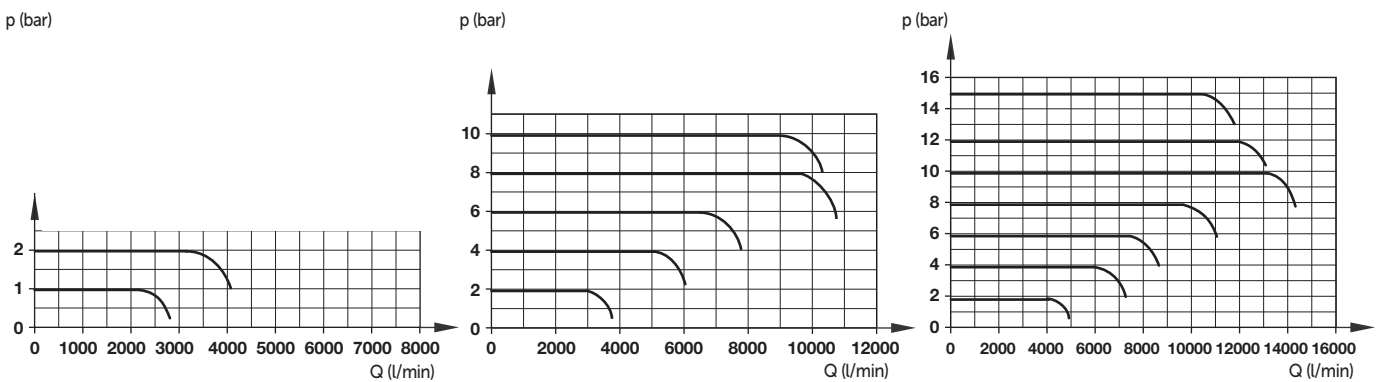

Flow rate characteristics DN16/connection plate 3/4" (DN20); P1=7 bar, 12 bar, 17 bar

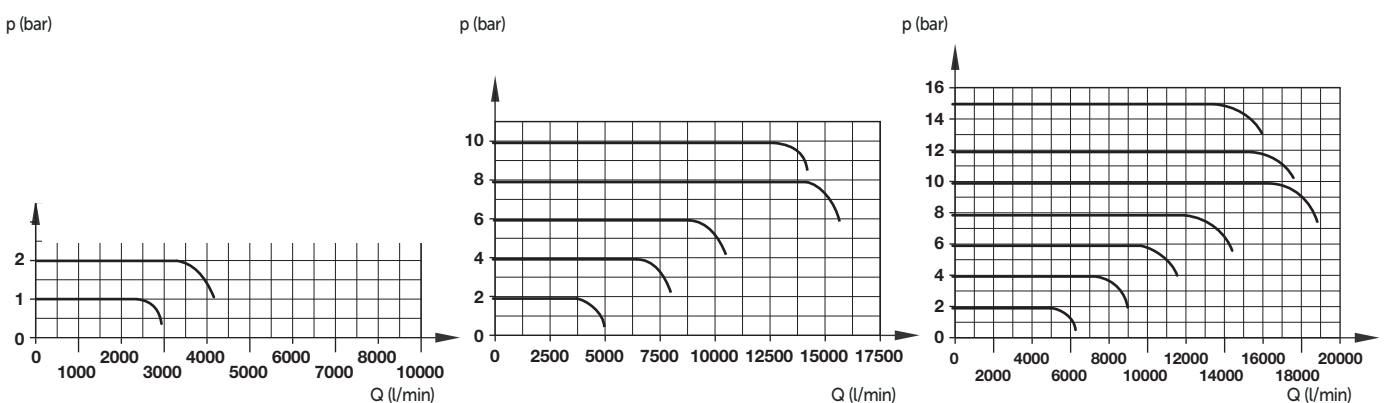

Functional descriptions Status LED and Controller gain

General display Status LED

Status	Status-LED
Device off	off
Device running	solid green
Valve malfunction*	red*
Output current max	red*

*Potential error sources of error:

- Power supply or internal references out of range.
- Valve not controllable (X≠W time out)
- Program sequence interrupted

Connection Diagrams

1. Analogue Version (M12x1, 8-pin)

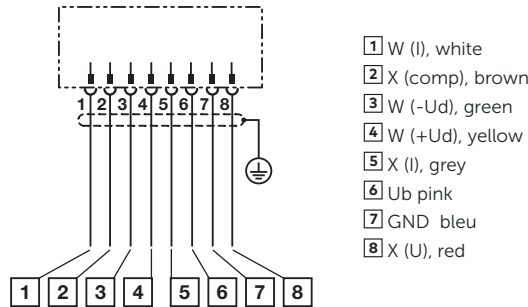

Setting controller gain via PC with VP-Tool

The gain of the integrated controller is factory preset to a default value. This allows an universal use of the valve.

If necessary, the controller gain can be varied to allow a specific compressed air application.

If the plug at the connector is opened, the USB interface can be used to adjust certain controller parameters using VP-Tool.

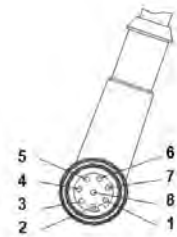

Assignment Supply:

Pin	Description	Color connection cable
6	Ub Power supply 18 ... 32 V DC	pink
7	GND Power ground/PGND	blue

Input Setpoint:

Pin	Description	Color connection cable
3	-W Analogue GND /Setpoint Voltage 0 ... 10 V	green
4	+W Signal/Setpoint Voltage 0 ... 10V	yellow
1	W(I) Setpoint current 4 ... 20 mA	white

Depending on the order number, only the ordered input is active, but both outputs (U/I) are active. Voltage input 0 to 10V between pins 4(+) and 3(-); Current input between pins 1(+) and 7(-).

Output Actual value:

Pin	Description	Color connection cable
5	X(I) Actual value current 4 ... 20 mA	grey
8	X(U) Actual value voltage 0 ... 10V	red

The voltage output refers to GNDS pin 3. (This means that due to the voltage drop on the GND pin 7, no loss of accuracy of the of the voltage output has to be considered). Both outputs are activated per default.

Comparator output/pressure switch*:

Pressure reached:

Pin	Description	Color connection cable
2	X (comp) Digital output signal PLC level (I max) =3.3 mA High: Pressure reached, deviation w-x < ± 2%. Low: pressure not reached, deviation w-x > ± 2%	brown

Output refers to Gnd pin 7

*Selectable via VP-Tool

2. USB interface connection (analogue Version)



Interface connection
Plug in USB cable, configuration via VP-Tool.

IO-Link Version:

LEDs and Controller parameters

LEDs	Description
1. IO-Link	Flashes green when IO-Link connection exists
2. SF (Valve status)	green: Status ok (status byte = 0); red: error status (status byte > 0: various causes)
3. VS	green: voltage ok; red: voltage missing or too low
4. VA	green: voltage ok; red: voltage missing or too low

Adjustment controller gain via IO-Link

The gain of the integrated controller is factory preset to a default value.

This allows an universal use of the valve.

If necessary, the controller gain can be varied to allow a specific compressed air application.

Specific parameters can be configured via IO-Link (during operation) or via USB interface by VP-Tool (default setting).

Connection Diagrams

3. IO-Link connection (M12x1, 5-pin) - Port Class B

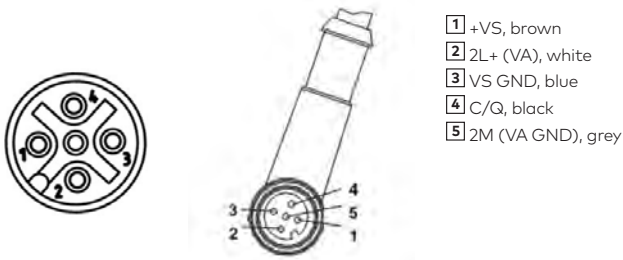

Assignment

Pin	Description	Color connection cable
1	VS	Power supply +18 ... 32 V DC
2	2L+ (VA)	Power supply +18 ... 32 V DC
3	VS GND	Power ground VS / GND
4	C/Q	IO-Link signal cable
5	2M (VA GND)	Power ground/GND

Connecting plugs analogue version



Description	Model
Cable 8 Pin M12 - Open End x 5 metre long, straight	0250811
Cable 8 Pin M12 - Open End x 5 metre long, 90°	0250813
Adaptor 8 Pin M12 - convertible, 90°	0252383

Note: Cable material PUR shielded

Connector IO-Link version



Description	Model
Cable 5 Pin A-coded M1 - M12 x 0.6 metre long	NC-125FS-125MS-A
Cable 5 Pin A-coded M12 - M12 x 1 metre long	NC-125FS-125MS-1
Cable 5 Pin A-coded M12 - M12 x 2 metre long	NC-125FS-125MS-2
Cable 5 Pin A-coded M12 - M12 x 5 metre long	NC-125FS-125MS-5
Cable 5 Pin A-coded M12 - Open End x 5 metre long	NC-125FS-00000-5

Connection plates



Description	Ports	Model
Connection plate DN8	G1/4	0542636
Connection plate DN8	G3/8	0543705
Connection plate DN16	G1/2	0542814
Connection plate DN16	G3/4	0542840

Serial interface accessories



Description	Model
USB-C interface cable	0253875

Dimensions
Analogue DN8

Dimensions in mm
Projection/First angle

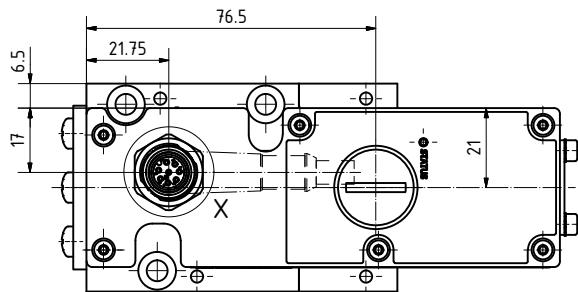
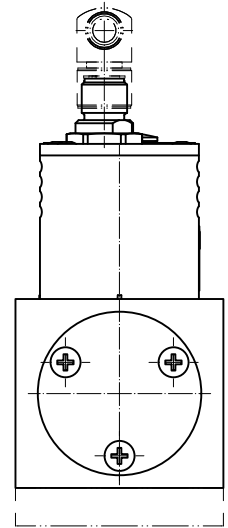
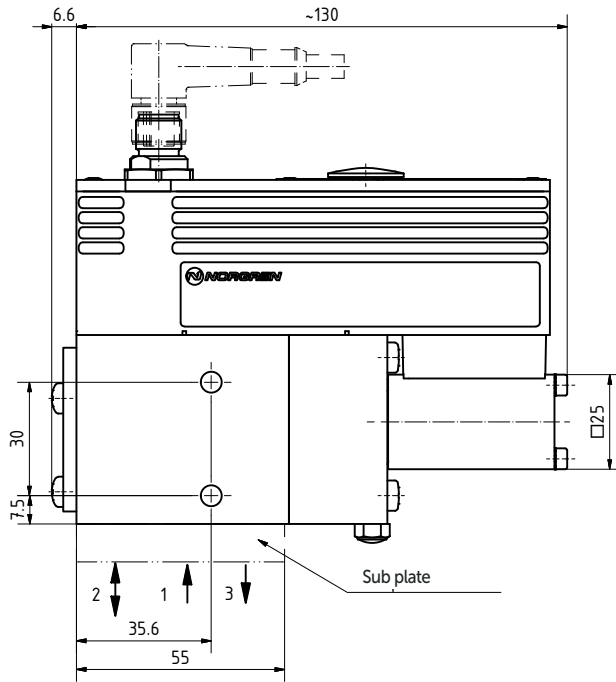
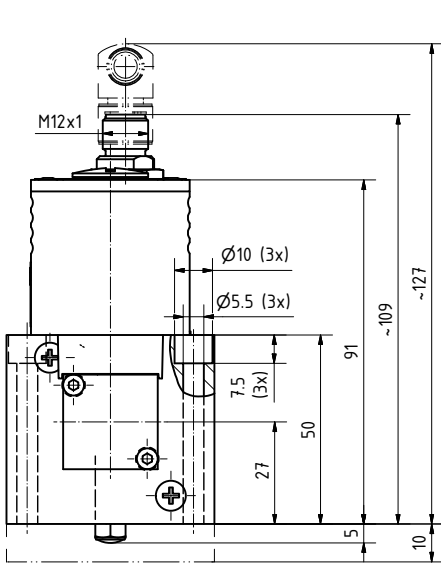
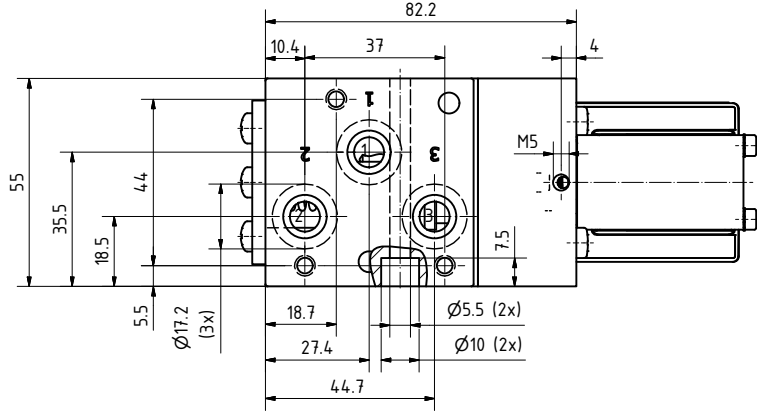

Dimensions
Analogue DN16

Dimensions in mm
Projection/First angle

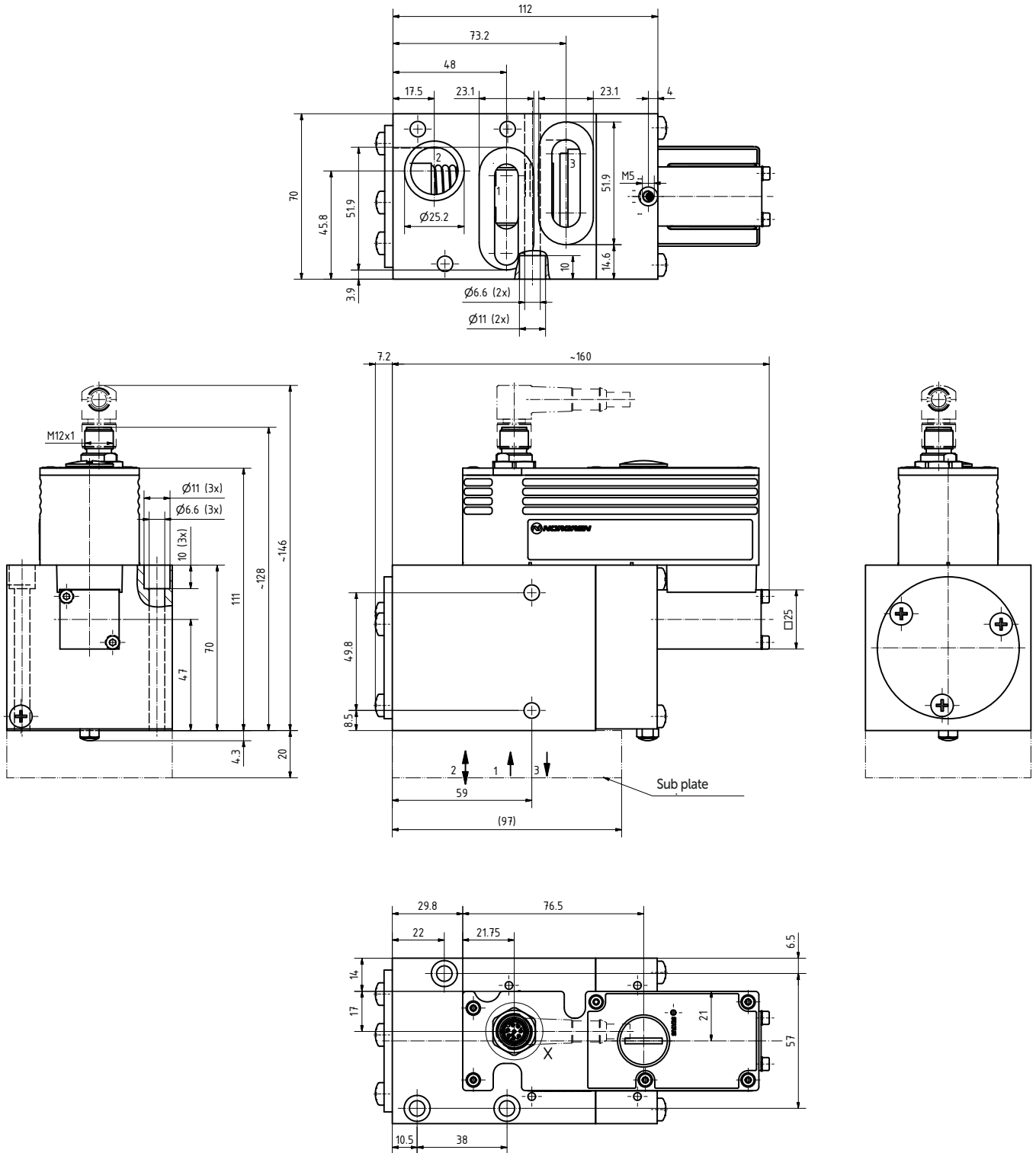

Dimensions
IO-Link DN16

Dimensions in mm
Projection/First angle

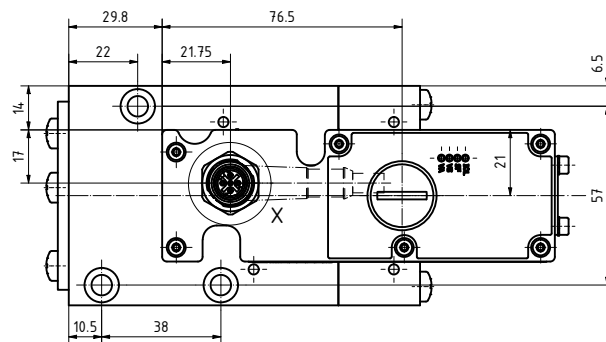
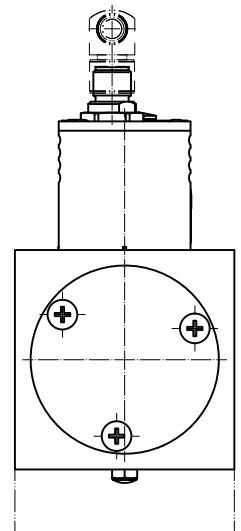
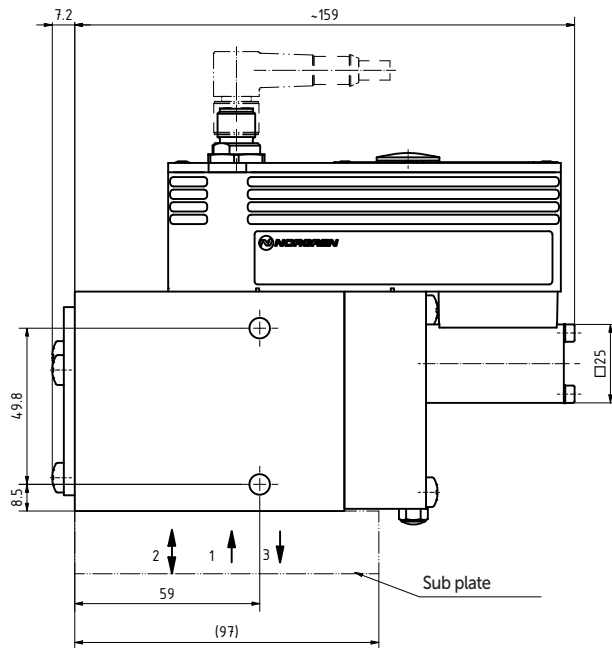
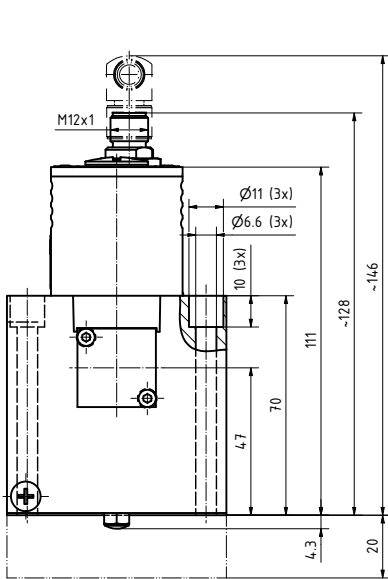
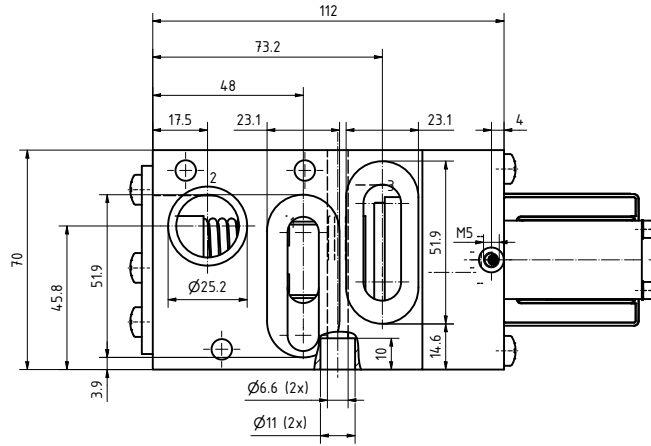

Connection plate
Model 0543705, DN8, G3/8 ports preferable for VP23xxBDxx1xxxxx valve

Dimensions in mm
 Projection/First angle

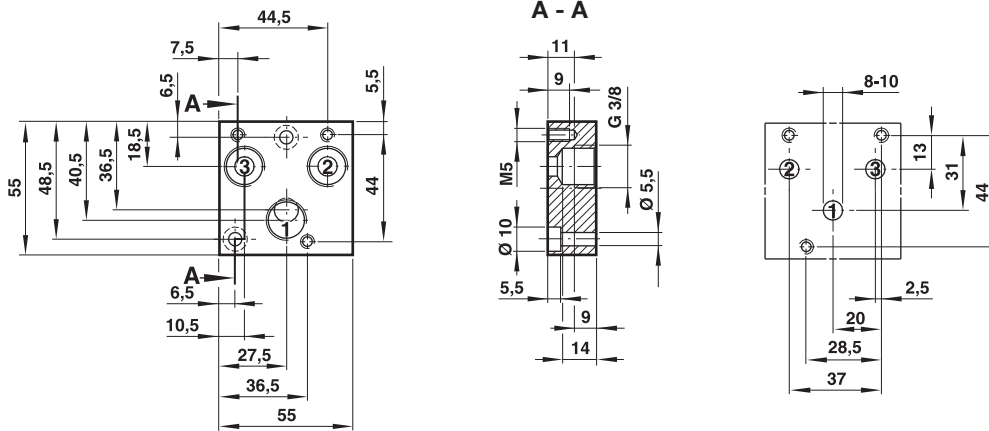

Model 0542636, DN8, G1/4 ports optional for VP23xxBDxx1xxxxx valve

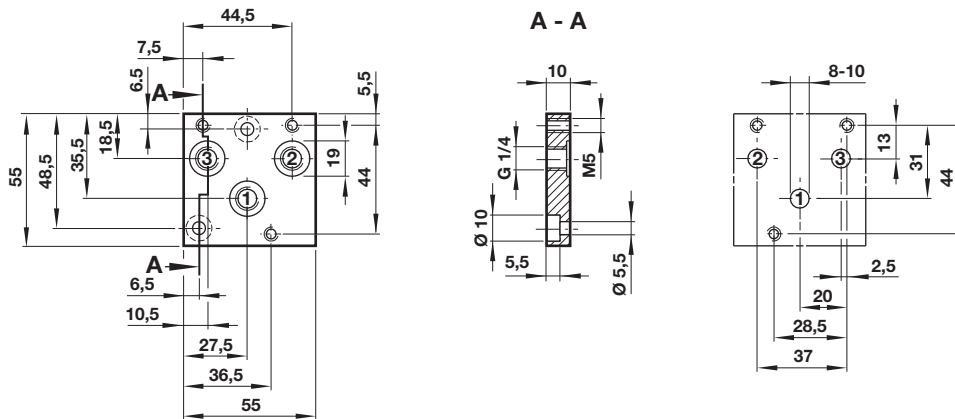

Model 0542840, DN16, G3/4 ports preferable for VP23xxBExx1xxxxx valve

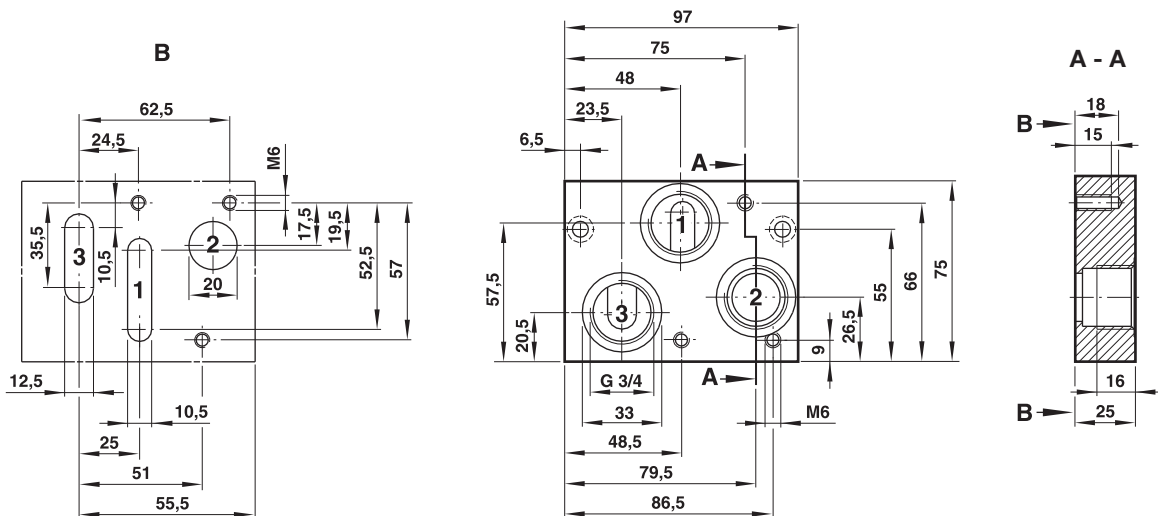

Connection plate
Model 0542814, DN16, G1/2 ports optional for VP23xxBExx1xxxxx valve

Dimensions in mm
 Projection/First angle

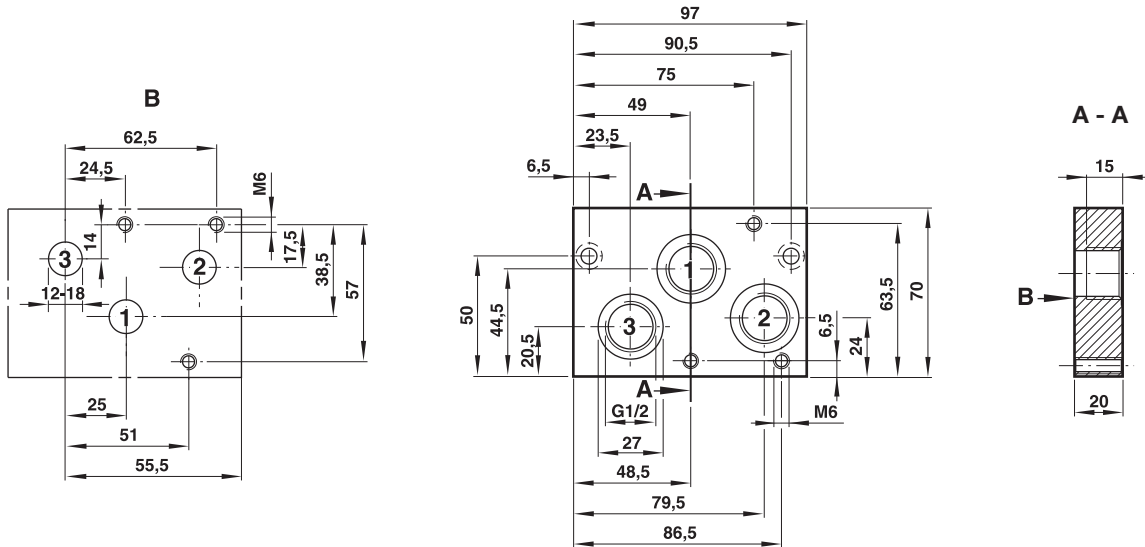

Warning

These products are intended for use in industrial compressed air systems only. Do not use these products where pressures and temperatures can exceed those listed under »**Technical features/data**«.

Before using these products with fluids other than those specified, for non-industrial applications, life-support systems or other applications not within published specifications, consult Norgren Ltd.

Through misuse, age, or malfunction, components used in fluid power systems can fail in various modes.

The system designer is warned to consider the failure modes of all component parts used in fluid power systems and to provide adequate safeguards to prevent personal injury or damage to equipment in the event of such failure.

System designers must provide a warning to end users in the system instructional manual if protection against a failure mode cannot be adequately provided.

System designers and end users are cautioned to review specific warnings found in instruction sheets packed and shipped with these products.