

3-Phase electronic reversing contactor

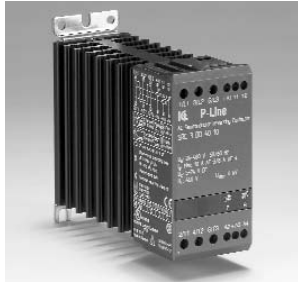

- Rated operational voltage up to 480 VAC 50/60Hz
- Rated operational current up to 10A AC-3
- Two independent control inputs with mutual interlock
- Control voltage from 5-24VDC or 24-230VAC/DC
- LED Status indication
- Meets EN 60947-4-2 requirements
- Requires only 45 mm DIN rail space

Item selection and technical specifications

Load ratings AC-53 motor load stand. AC-4 motor load inching / plugging	Control voltage	Item number by 24-480VAC 50/60Hz Line Voltage	Module-width
10A AC-53 / 8A AC-4	5-24 VDC	SRC 3 DD 4010	45mm
10A AC-53 / 8A AC-4	24-230 VAC/DC	SRC 3 DA 4010	45mm

Output load specification

Operational current AC-3	10A	Leakage current	5mA ACmax.
Operational current AC-4	8A	Min. operational current	50mA
Duty cycle	100%		

Control terminal specifications

SRC 3 DD 4010		SRC 3 DA 4010	
Control voltage	5 - 24 VDC	Control voltage	24- 230 VAC/DC
Pick-up voltage max.	4.25 VDC	Pick-up voltage max.	20.4 VAC/DC
Drop-out voltage min.	1.5 VDC	Drop-out voltage min.	7.2 VAC/DC
Control current	25mA @ 4VDC	Control current / power max.	6mA / 1.5VA@24VDC
Response time max.	1/2 cycle	Response time max.	1cycle
Interlock time max.	80 msec.	Interlock time max.	150 msec.

Thermal specification

Power dissipation for continuous operation PDmax	2.2 W/A	Operation in ambient temperatures exceeding 40°C is possible if the power dissipation is limited either by reducing the steady-state current or by reducing the duty-cycle of the contactor as shown in the table. Max.cycle time 15min.
Power dissipation for intermittent operation PD	2.2 W/A x dutycycle	
Cooling method	Natural convection	
Mounting	Vertical +/-30°	
Operating temperature range EN 60947-4-2	-5C° to 40°C	
Storage temperature EN 60947-4-2	-20C° to 80°C	
Max. operating temperature with current derating	60°C	

Insulation specifications

Rated insulation voltage	Ui 660 Volt
Rated impulse withstand voltage	Uimp. 4 kVolt
Installation category	III

Functional diagram

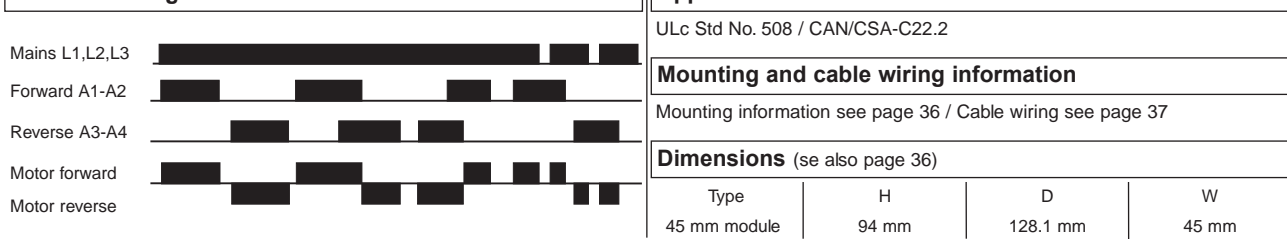

Approval

ULc Std No. 508 / CAN/CSA-C22.2

Mounting and cable wiring information

Mounting information see page 36 / Cable wiring see page 37

Dimensions (se also page 36)

Type	H	D	W
45 mm module	94 mm	128.1 mm	45 mm

3-Phase electronic reversing contactor

Wiring specifications

SRC 3 DX 4010

For UP 62 or other wiring purposes

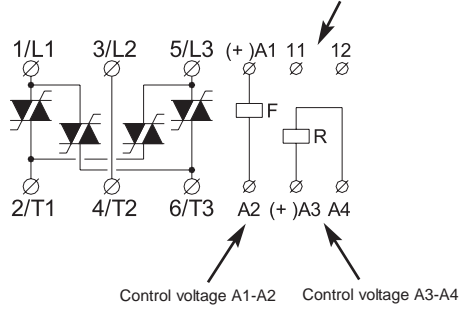

Combining Reversing Electronic Contactor & Soft Starter

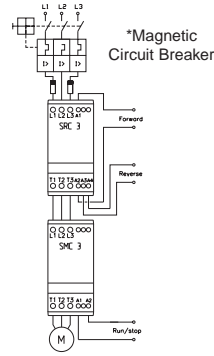

Soft-reversing of motors up to 10A

A Soft-Reversing of a motor can easily be achieved by connecting a reversing relay to the Soft Starter. The reversing relay type SRC 3 DX will determine the direction of rotation Forward or Reverse and the Soft Starter type SMC 33 DA XXXX will perform soft-starting and soft-stopping of the motor. If soft-stop is not required the application can be simplified by connecting the control circuit of the Soft Starter to the main terminals as shown under Line Controlled Soft-Start. A delay of approx. 0.5 sec. between forward and reverse control signal must be allowed to avoid influence from the voltage generated by the motor during turn Off.

Short-circuit protection by circuit breaker or fuses

Two type of short-circuit protection can be used:

- Short-circuit protection by circuit breaker.
- Short-circuit protection by fuses.

Short-circuit protection is divided into 2 levels **Type 1** or **Type 2**

Co-ordination Type 1: Short-circuit protects the installation

Co-ordination Type 2: Short-circuit protects the installation and the semiconductors inside the motor controller

a) Short-circuit protection by circuit breaker

A 3-Phase motor with correctly installed and adjusted overload relay will not short circuit totally to earth or between the 3 phases. Part of the winding will normally limit the short circuit current to a value that will cause instantaneous magnetic tripping of the circuit breaker without damage to the electronic contactor. The magnetic trip response current is approx. 11 times the max. adjustable current.

b) Short-circuit protection by fuses

- Type 1: SRC 3 DX 4010 Protection max. 50 A gL/gG
 Type 2: SRC 3 DX 4010 Protection max. 1.2t of the fuse 610 A2S

Fuses from e.g. Ferraz, Siba, Bussmann can be used as short-circuit protection Type 2
 More information concerning Co-ordination Type 2 see page 37

Overload Protection in Motor Control Reversing

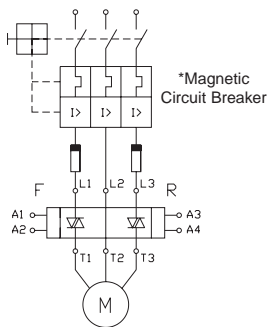

Overload protection of the motor is easily achieved by installing a manual thermal magnetic circuit breaker on the supply side of the motor. The circuit breaker provides means for padlocking and the necessary clearance for use as a circuit isolator according to EN 60204-1.

Adjust the current limit on the MCB according to the rated nominal current of the motor
 *Use UL approved Magnetic Circuit Breaker or UL specified back-up fuse type K5 or H Class

Thermal overload protection (see also page 36)

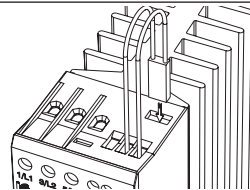

Optional thermal overload protection is possible by inserting a thermostat in a slot on the right hand side of the contactor. Type number UP62

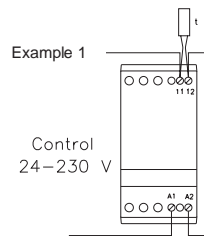

The thermostat can be connected in series with the control circuit of the contactor. When the temperature of the heatsink exceeds 90°C the soft starter will switch Off.
Note: When the temperature has dropped approx. 30°C the contactor will automatically be switched on again.

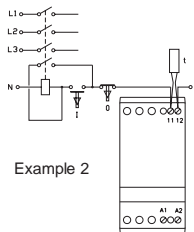

The thermostat is connected in series with the control circuit of the main contactor. When the temperature of the heatsink exceeds 90°C the main contactor will switch Off. A manual reset is necessary to restart this circuit.

Utilisation Categories EN60947-4-2

Category AC-53: Starting, switching off motors during running

Category AC-4: Starting, plugging, reversing the motors rapidly while the motor is during.

EMC

This component meets the requirements of the product standard EN60947-4-2 and is CE marked according to this standard.