

ifm electronic



Installation instructions
Compact speed monitor M30
AC/DC version

UK

ecomat200[®]

DI01xx

DI1xxA

80235738 / 00 03 / 2016

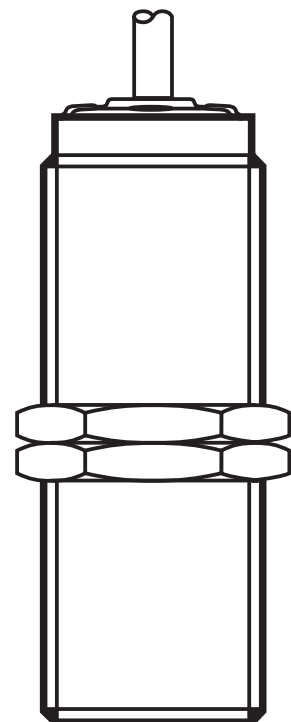

Contents

1 Preliminary note.....	2
1.1 Symbols and warning signs used.....	3
2 Safety instructions.....	3
2.1 ATEX units (DI1xxA).....	3
3 Functions and features.....	3
3.1 Switching function.....	3
3.2 Function diagram.....	4
4 Installation.....	5
5 Electrical connection.....	5
6 Setting.....	6
7 Operation.....	6
8 Technical data.....	7

1 Preliminary note

This document applies to devices of the type "compact speed monitor" (art. no.: DI01xx and DI1xxA).

This document is intended for specialists. These specialists are people who are qualified by their training and their experience to see risks and to avoid possible hazards that may be caused during operation, installation or maintenance of the device.

Read this document before use to familiarise yourself with operating conditions, installation and operation. Keep this document during the entire duration of use of the device.

WARNING

Adhere to the warning notes and safety instructions (→ 2 Safety instructions).

1.1 Symbols and warning signs used

► Instructions

→ Cross-reference



Information

Supplementary note.



Important note

Non-compliance can result in malfunction or interference.

WARNING

Warning of serious personal injury.

Death or serious irreversible injuries may result.

UK

2 Safety instructions

The sensor must be connected by a qualified electrician. Observe the national and international regulations for the installation of electrical equipment.

2.1 ATEX units (DI1xxA)

Remarks for safe use in hazardous areas: operating instructions (Ex protection related part) for speed monitors according to EU directive 2014/34/EC annex VIII (ATEX) group II, equipment category 3D.

If no operating instructions (Ex protection related part) or EC declaration of conformity is supplied with this product in the language of the EU user country, these can be requested from your dealer (see delivery note) or manufacturer (see cover sheet / back).

3 Functions and features

The compact inductive speed monitor detects without contact if a set rotational speed is not reached and signals this by means of a switching signal.

3.1 Switching function

Transistor output	LEDs	
switched (conducting)	On	rotational speed > SP and during start-up delay
not switched (non conducting)	Off	rotational speed < SP

SP = set point

3.2 Function diagram

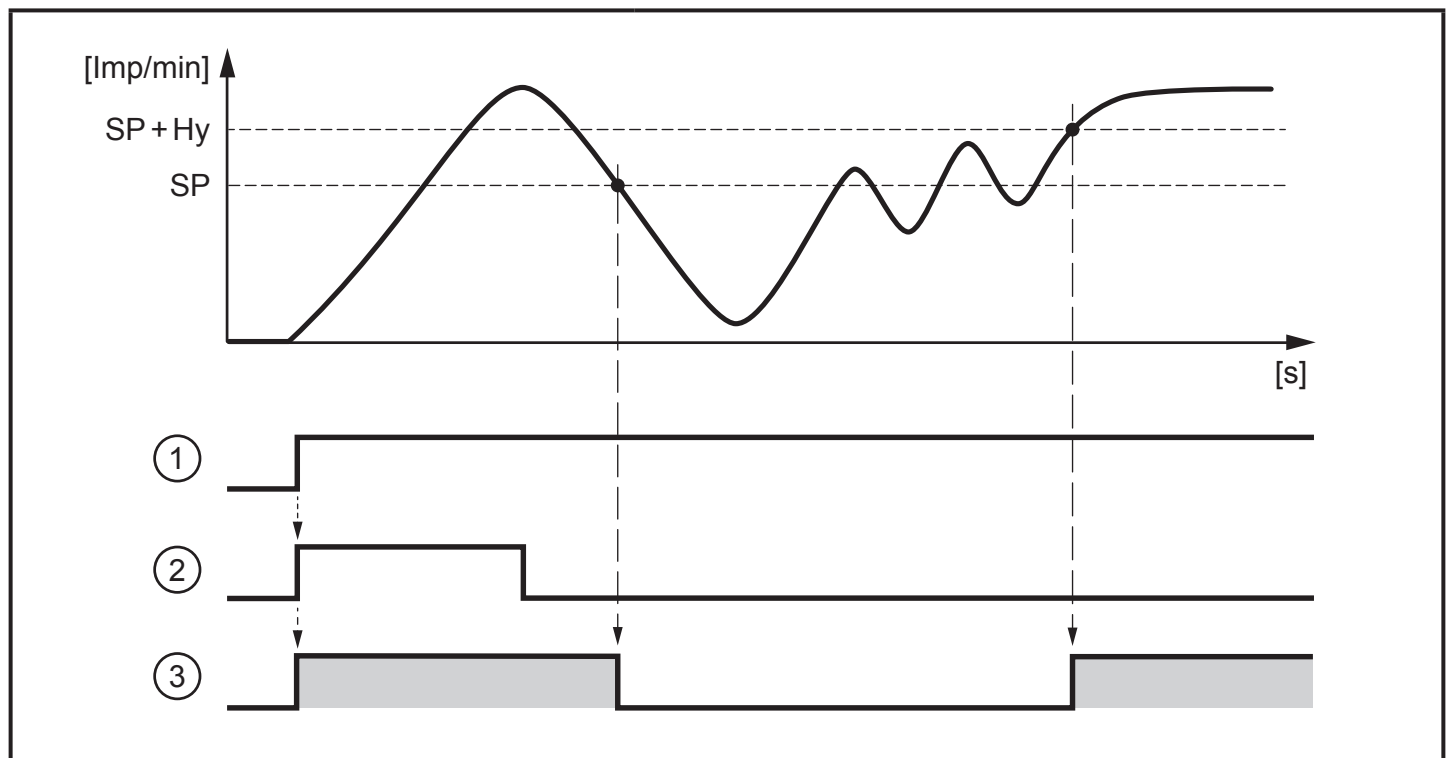

- 1: voltage supply
- 2: start-up delay
- 3: transistor output

SP = switch point
Hy = hysteresis

■ = transistor output switched (conductive)



The start-up delay suppresses an error signal as long as the machine is in the process of starting and has not yet reached its minimum speed. After application of the operating voltage the start-up delay is active only once. If the drive is often turned on and off, couple the supply voltage of the drive and the monitor. By doing so, the start-up delay is active every time the motor is turned on.

4 Installation

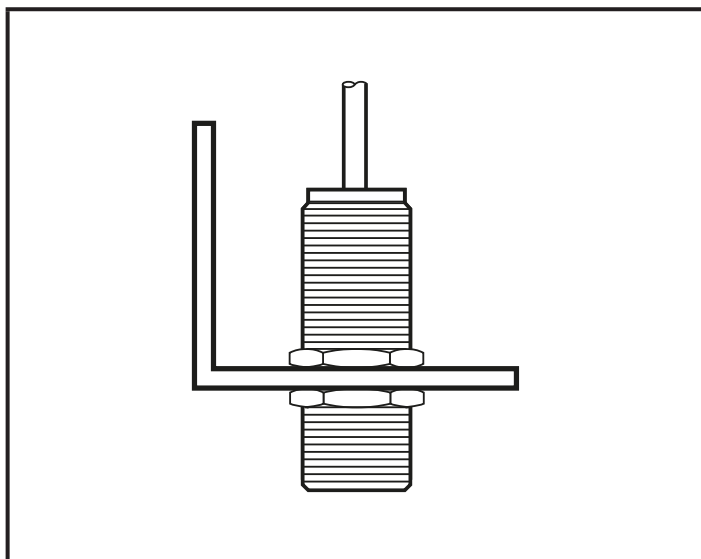

Mounting principle

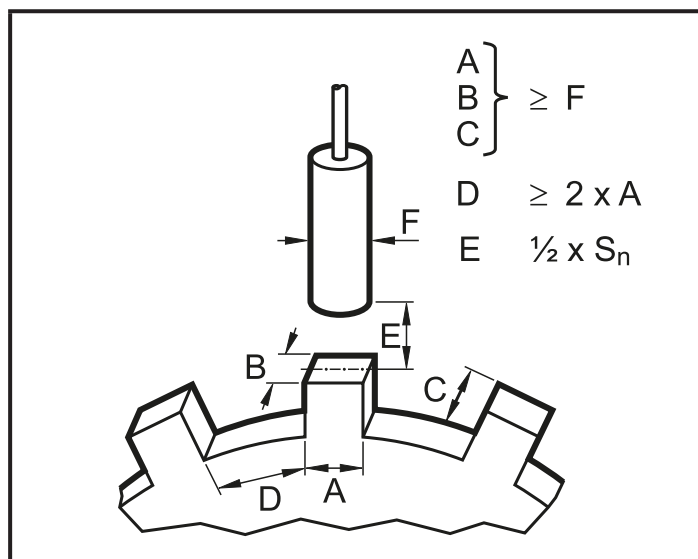

Mounting specifications

- ▶ Fix the unit by means of a mounting device and secure it by means of the nuts provided so that it cannot work loose.
Flush installation.
- ▶ Adhere to the above mounting specifications to ensure a correct function.
Nominal sensing range S_n (→ 8 Technical data)

5 Electrical connection

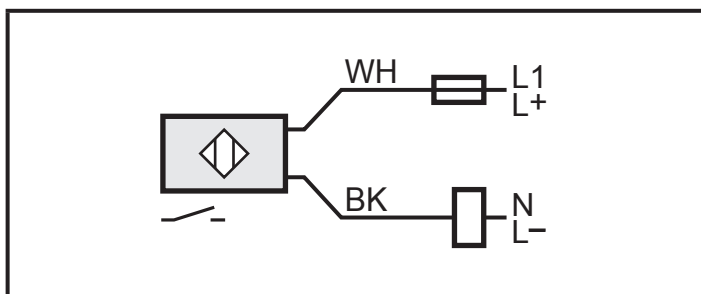

BK = black
WH = white

Wiring

- ▶ Disconnect power.
 - ▶ Connect the device according to the wiring arrangement.
- !** Miniature fuse to IEC60127-2 sheet 1, ≤ 2 A (fast acting)
ATEX units (DI1xxA):
Place the fuse outside the hazardous area.

6 Setting

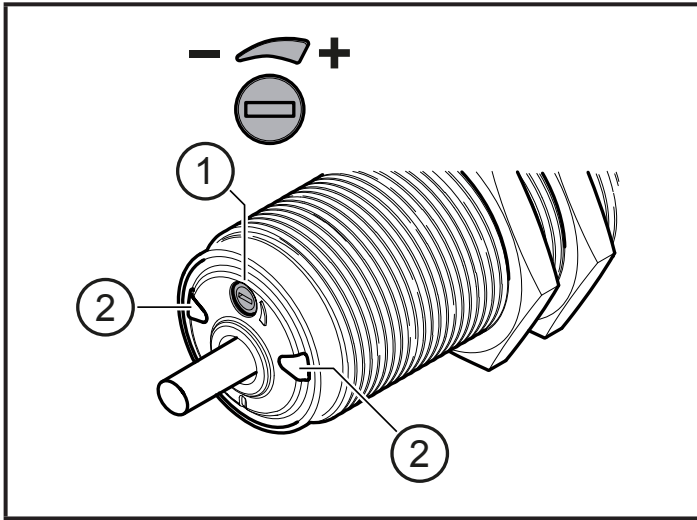

- 1: Multi-turn potentiometer for switch point setting (without end stop)
- 2: LEDs for switching status indication (→ 3.1 Switching function)

Operating and display elements

- ▶ Keep the minimum speed to be monitored in the plant on a constant level.
- ▶ Switch on the device.
- ▶ Wait until the start-up delay is over (→ 8 Technical data).
- ▶ Set the switch point depending on the status of the LEDs.

If the LEDs are not lit:

- Turn the pot slowly anticlockwise (-) until the LEDs are lit.
Setting is finished.

If the LEDs are lit:

- Turn the pot clockwise (+) until the LEDs go off.
- Turn the pot slowly anticlockwise (-) until the LEDs are lit.
Setting is finished.

7 Operation

The operation is maintenance-free.

Ensure the following for a correct function:

- ▶ Keep the sensing face and the open space free of metal deposits and foreign bodies.
- ▶ Do not operate units with high field intensity (e.g. mobile phones) at close range to the speed monitor.

8 Technical data

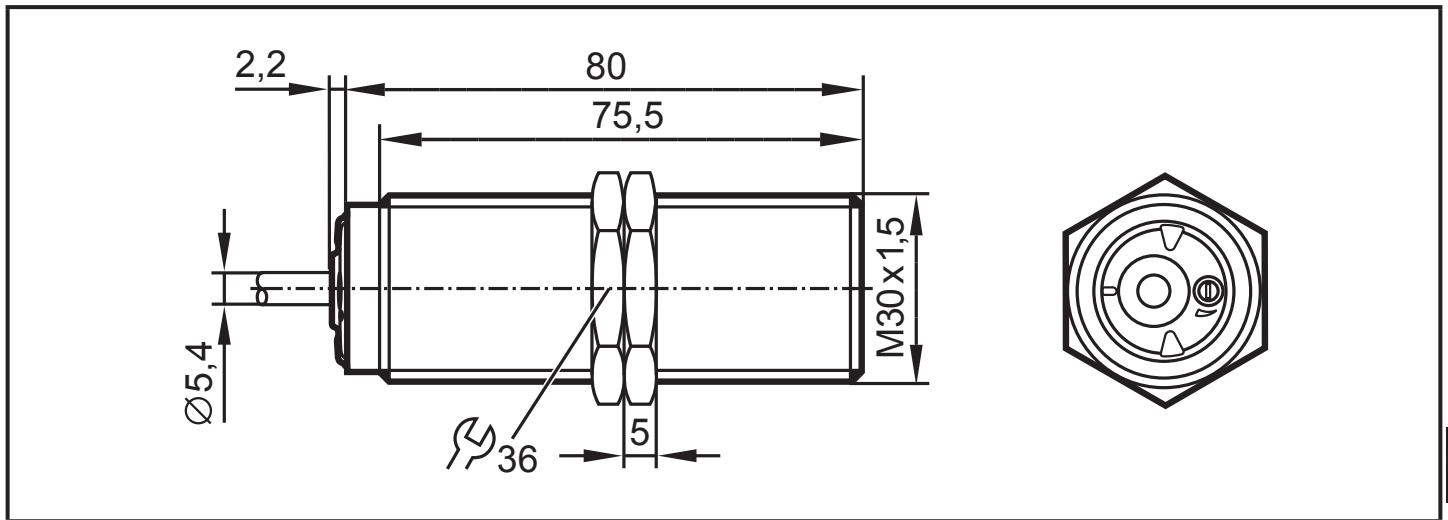

Dimensions [mm]

		DI0101	DI0104	DI103A
Nominal voltage	[V]	20...250 AC/DC (45...65 Hz, AC)		
Current rating (continuous)	[mA]	350 AC, 50 °C 250 AC, 80 °C 100 DC, 80 °C		200 AC, 60 °C 100 DC, 60 °C
Current rating (peak)	[mA]	2200 (20 ms / 0.5 Hz)		
Minimum load current	[mA]	> 6		
Leakage current	[mA]	< 1.5		
Voltage drop	[V]	< 7.5		
Reverse polarity protection		yes		
Short circuit / overload protection		no / no		
Nominal sensing range (Sn)	[mm]	10		
Operating distance (Sa)	[mm]	0...8.1		
Setting range	[pulses/min]	5...3600		
Hysteresis	[% of SP]	10		
Start-up delay	[s]	12	< 0.5	12
Damping frequency	[pulses/min]	≤ 4800 (for Sn/2)		
Ambient temperature	[°C]	-25...80		-20...60
Protection		IP 65 / IP 67 / II		
ATEX equipment category		-		3D
Connection		PUR cable / 2 m; 2 x 0.5 mm ²		

Data sheets and EC declarations of conformity can be found at:
www.ifm.com → Data sheet search → Article number